

SCOTSMAN

UNDER COUNTER FLAKER WITH STORAGE

A F E 3 2 5

VOLUME PRODUCTION • 24 HOUR

Based on Air/Water Temperatures	Air-Cooled	
	70°/50° lbs./kg.	90°/70° lbs./kg.
AFE325	324/147	264/120



DEPENDABLE PERFORMANCE IN ANY CONDITION

- Continuous ice-making process...no harvest time delays.
- Delivers steady flow of ice for fast recovery of ice supply.
- One heavy duty flaker mechanism with a stainless steel auger.
- Low-refrigerant safety switch.
- Stainless Steel Exterior.

WARRANTY See your dealer for complete warranty details.

- 2 years parts on all component.
- 2 years labor on all component parts.
- 5 years parts on the compressor.

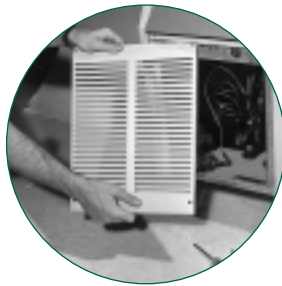

COMPLETE FRONT SERVICE

All machine components are in a convenient slide-out module behind an easily removable front panel. Keeps service cost and machine down-time to a minimum.

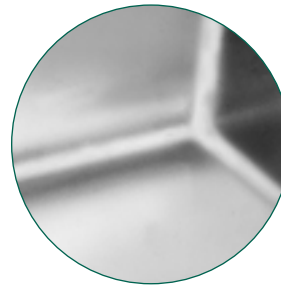

BIN INTERIOR

The polyethylene bin interior is sanitary and easy to clean. Resists scratches and scuffs from ice scoops.

This product qualifies for the following listings:



 **Scotsman**[®]

Ice Machine Specifications

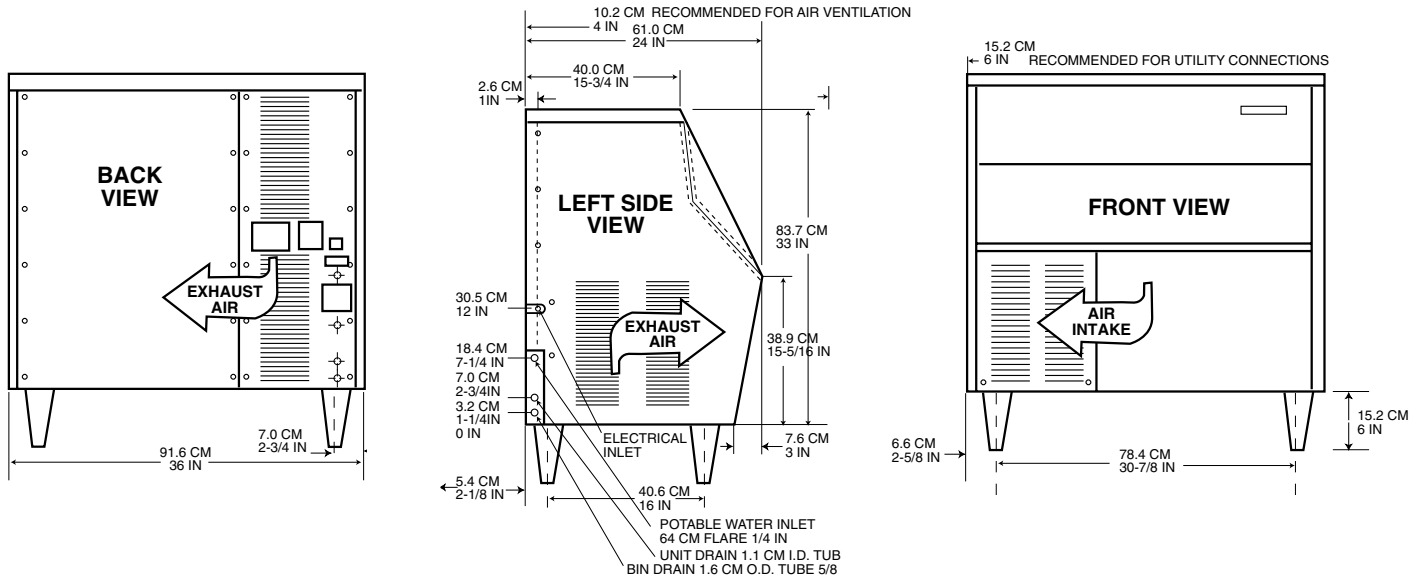

INSTALLATION NOTE: Allow 6" minimum space at left side and back for ventilation and utility connections.

All models: Dimensions: W x D x H without legs (Add 6" height for legs): Unit: 36¹/₁₆" x 24" x 33" Shipping Carton: 39¹/₂" x 27¹/₂" x 38¹/₂"

Model Number	Condenser Unit	Bin Cap. lbs./kg.	Basic Electrical Volts/Hz/Phase	Max. Fuse Size or HACR Circuit Breaker	Comp. HP	Circuit Wires	Min. Circuit Ampacity	Shipping Weight lbs./kg.	Power Consumption KWH/100 lbs. 90°F/70° F	Water Usage Gallons/100 lbs.	
										Potable 90°F/70° F	Condenser 90°F/70° F
AFE325AS-1A	AIR	140/64	115/60/1	15	1/4	2	9.6	215/98	5.6	12.0	-

All units with Stainless Steel finish.
 Refrigerant: R-134A.

LEGS SUPPLIED:
 Four black plastic legs screw into mounting plates on cabinet base.
 Provide 6" minimum height including adjustable leveling foot.

Scotsman's ice machines are not designed for outdoor installations. Scotsman remote condensers are designed for outdoor installations.

Machine requires voltage indicated on rating name plate. Failures caused by improper voltage are not considered factory defects. Extended periods of operation at temperatures exceeding limitations constitutes misuse under the terms of Scotsman Manufacturer's Limited Warranty, resulting in a loss of warranty coverage. Specifications and design are subject to change without notice.

Consult Your Local SCOTSMAN Representative At:

IMPORTANT OPERATING REQUIREMENTS:

	Minimum	Maximum
Air Temperatures	50°F (10°C)	100°F (37.7°C)
Water Temperatures	40°F (4.4°C)	100°F (37.7°C)
Water Pressures	20 PSIG	120 PSIG
Electrical Voltage	-5%	+10%

YOU'LL VALUE THE DIFFERENCE™

775 Corporate Woods Parkway • Vernon Hills, IL 60061 • 1-800-SCOTSMAN • (847) 913-9844
 Visit our website at: www.scotsman-ice.com • E-mail: customer.service@scotsman-ice.com

